

Submittal Data Sheet

Specification

The NFPA 99 compliant digital, fully automatic manifold shall be a Tri-Tech Medical Genesys™ CC series. No manual resetting of valves or levers shall be required. The unit shall switch from “Bank in Use” to “Reserve” bank without fluctuation in line delivery pressure. Simultaneously, the “Reserve in Use” alarm shall be triggered by the manifold’s microprocessor. The manifold shall continue to provide gas, in the event of a power failure, until both banks are depleted. After the switchover, the “Reserve” bank shall then become the “Bank in Use”. The manifold microprocessor shall also trigger the “High Line Pressure” and “Low Line Pressure” alarms without the need for additional pressure switches or transducers. The manifold shall be capable of being upgraded after installation, to be used with low or medium pressure portable bulk vessels or for use at higher or lower delivery pressures.

The microprocessor based control panel shall incorporate LED’s and an illuminated text display and shall provide electronic monitoring of circuits with up to 20 error, alarm or information messages displayed for ease of maintenance. The illuminated text display shall be readable even in poor lighting conditions. Analog gauges are also provided so that line and both bank pressures may be observed in the event of a power failure. The control panel shall also incorporate a set of LED’s for each bank, green for “Bank in Use”, amber for “Ready” and red for “Empty”.

All manifold regulators, piping and control switching equipment shall be cleaned for use with oxygen service and installed in a steel powder coated cabinet (weatherproof version available) to provide protection and minimize tampering.



Model CCU12NO1W shown above

Features - Benefits

- **Five year parts and one year labor limited warranty***
- Line pressure sensor may be mounted inside the cabinet or remotely located “by purchasing an optional PSM-XX assembly” to eliminate the need for a high/low pressure switch for master alarm operation.
- Electronic monitoring of circuits with up to 20 error, alarm or information messages.
- May be converted from high pressure cylinder use to use with low or medium pressure liquid portable bulk vessels.
- Includes 3/4" source or main line ball valve with copper tube extension, Ref. Tri-Tech part no. 48-0023.
- Optional single point relief valve vertical kit part no. 88-1075.
- Unit of measure switching (psi, kPa, BAR).
- **OSHPD** Seismic tested and Certified
- Dual line pressure regulators
- Double “Z” brackets for one-man installation.
- Cabinet weight 70 lbs.
- Input power 120 to 240 VAC, 50 to 60 Hz – single point connection.
- Maximum Inlet Pressure 3000 psi
(Note: Inlet bank transducer proof pressure is 10,000 psi but will only display pressure up to 2500 psi accurately)

*** See Terms and Conditions, Document No. 99-0477, on our Website at: www.tri-techmedical.com. For complete details.**

Genesys is a registered trademark of Tri-Tech Medical. Patented.

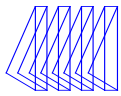

Maximum rated flow capacity of line regulators only, not the manifold cabinet, flowing to atmosphere. (Without restricting line pressure drop)

<i>Gas Service</i>		<i>Standard Line Regulators</i>	<i>High Capacity Line Regulators</i>
Oxygen or Medical Air	<i>Delivery Pressure and Flow Option</i>	1L	1H, 2H, 3H
		2,500 SCFH (1,180 l/min)	4,500 SCFH (2,120 l/min)
Nitrogen	<i>Delivery Pressure and Flow Option</i>		3H
		N/A	6,000 SCFH (2,830 l/min)

Maximum recommended flow due to the chill down nature of the gas.

<i>Gas Service</i>		<i>Without Heaters</i>	<i>With Heaters</i>
Nitrous Oxide or Carbon Dioxide	<i>Delivery Pressure and Flow Option</i>	1L	1W, 1X
		40 SCFH (19 l/min)	500 SCFH (236 l/min)

Note:
1W – Models incorporate **1L** Line Regulators
1X – Models incorporate **1H** Line Regulators

Manifold Cabinet Flow Capacity

<i>Static Delivery Pressure Setting psi</i>	<i>Pressure Drop</i>	<i>Pressure Flowing psi</i>	<i>Manifold Line Regulator Delivery Pressure and Flow Option</i>			
			<i>Average Flow Rate in SCFH (l/min)</i>			
			1L	1H	2H	3H
53	3	50	195 (92 l/min)	640 (302 l/min)		
	5	48	430 (203 l/min)	1,260 (595 l/min)		
	7	46	635 (300 l/min)	1,650 (779 l/min)		
	10	43	875 (413 l/min)	2,430 (1,147 l/min)		
85	3	82			1,010 (477 l/min)	
	5	80			1,610 (760 l/min)	
	7	78			2,670 (1,261 l/min)	
	10	75			3,120 (1,473 l/min)	
175	10	165				1,230 (581 l/min)
	20	155				2,535 (1,197 l/min)
	30	145				4,140 (1,955 l/min)
	35	140				4,500 (2,125 l/min)

Flow rates shown were obtained using Nitrogen, flowing through the right primary regulator, which is considered the most restrictive flow path. (Worst case condition). Testing was performed with an average inlet pressure to the manifold cabinet at 1,425 psi.

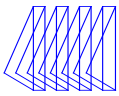

Dimensional Drawing

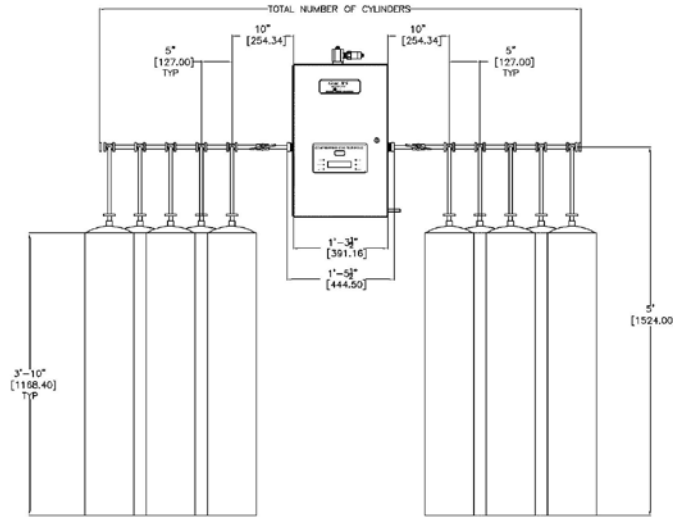

Design Lengths	Total Number of Cylinders	4	6	8	10	12	16	20
STAGGERED DESIGN (5" CENTERS)		4'-6"	5'-4"	6'-2"	7'-0"	7'-10"	9'-6"	11'-2"
OVERALL MANIFOLD LENGTH		(1.32m)	(1.63m)	(1.88m)	(2.13m)	(2.39m)	(2.90m)	(3.33m)
VERTICAL CROSSOVER (5" CENTERS)		3'-7"	N/A	4'-6"	N/A	5'-4"	6'-2"	7'-0"
OVERALL MANIFOLD LENGTH		(1.10m)	N/A	(1.32m)	N/A	(1.63m)	(1.88m)	(2.13m)

*See Separate Manifold Header Literature for Header Part Numbers

How to Order: Easy to use modular ordering system. Fill in the 7 blanks to specify the manifold that meets **your** needs.

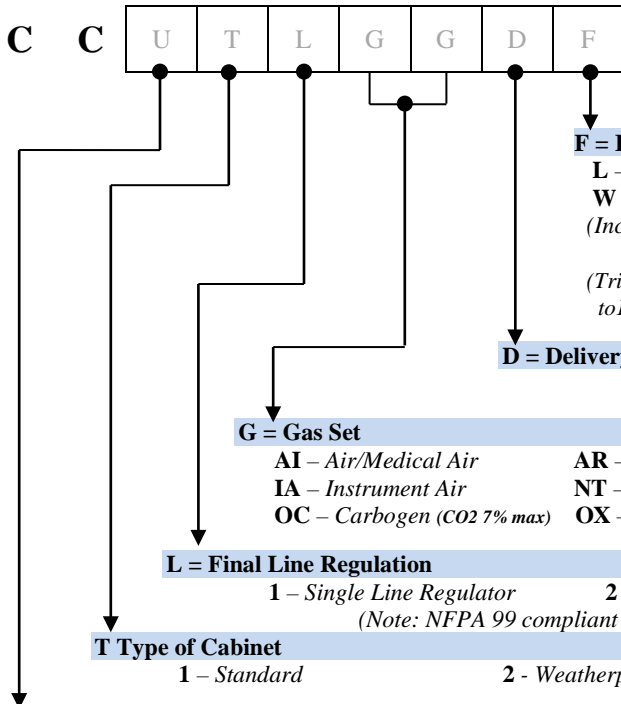

F = Flow and Heater Options (See Chart on Page 2 for flow capacities)
L – Standard Flow w/o Heaters **H** – High Flow w/o Heaters
W – Standard Flow with Heaters* **X** – High Flow with Heaters*
 (Incorporates 1L Line Regulator) (Can incorporate 1H, 2H, or 3H Line Regulators)
 (* Input voltage limited to 120 VAC for these Models)
 (Tri-Tech transformer kit Part No. 35-3004 [Sold Separately] reduces 240 VAC single phase to 120 VAC.)

D = Delivery Pressure
1 – 50 psi **2** – 80 psi **3** – 170 psi

G = Gas Set
AI – Air/Medical Air **AR** – Argon **CD** – Carbon Dioxide **HO** – Hyperbaric Oxygen
IA – Instrument Air **NT** – Nitrogen **NO** – Nitrous Oxide **NX** – N2O-Oxygen Mixtures
OC – Carbogen (CO2 7% max) **OX** – Oxygen **TG** – Tri-Gas

L = Final Line Regulation
1 – Single Line Regulator **2** – Dual Line Regulator
 (Note: NFPA 99 compliant manifolds require dual line regulators)

T Type of Cabinet
1 – Standard **2** – Weatherproof

U = Country
U – Tri-Tech Labeled NFPA Color Code English **I** – Tri-Tech Labeled ISO Color Code English/French
N – Tri-Tech Labeled NFPA Color Code English/Spanish

Example: CCU12OX1L = Cylinder x Cylinder Genesys™ Manifold, Standard Cabinet, Dual Line Regulators, CGA 540 Oxygen service, 50 psi delivery, Standard flow. High/Low line pressure sensor with DISS union demand check is included with all units.